

ISSN 2518-1491 (Online),
ISSN 2224-5286 (Print)

ҚАЗАҚСТАН РЕСПУБЛИКАСЫ
ҰЛТТЫҚ ҒЫЛЫМ АКАДЕМИЯСЫНЫҢ

Д.В. Сокольский атындағы «Жанармай,
катализ және электрохимия институты» АҚ

Х А Б А Р Л А Р Ы

ИЗВЕСТИЯ

НАЦИОНАЛЬНОЙ АКАДЕМИИ НАУК
РЕСПУБЛИКИ КАЗАХСТАН
АО «Институт топлива, катализа и
электрохимии им. Д.В. Сокольского»

NEWS

OF THE ACADEMY OF SCIENCES
OF THE REPUBLIC OF KAZAKHSTAN
JSC «D.V. Sokolsky institute of fuel, catalysis
and electrochemistry»

SERIES
CHEMISTRY AND TECHNOLOGY

6 (444)

NOVEMBER – DECEMBER 2020

PUBLISHED SINCE JANUARY 1947

PUBLISHED 6 TIMES A YEAR

ALMATY, NAS RK

NAS RK is pleased to announce that News of NAS RK. Series of chemistry and technologies scientific journal has been accepted for indexing in the Emerging Sources Citation Index, a new edition of Web of Science. Content in this index is under consideration by Clarivate Analytics to be accepted in the Science Citation Index Expanded, the Social Sciences Citation Index, and the Arts & Humanities Citation Index. The quality and depth of content Web of Science offers to researchers, authors, publishers, and institutions sets it apart from other research databases. The inclusion of News of NAS RK. Series of chemistry and technologies in the Emerging Sources Citation Index demonstrates our dedication to providing the most relevant and influential content of chemical sciences to our community.

Қазақстан Республикасы Ұлттық ғылым академиясы "ҚР ҰҒА Хабарлары. Химия және технология сериясы" ғылыми журналының Web of Science-тің жаңаланған нұсқасы Emerging Sources Citation Index-те индекстелуге қабылданғанын хабарлайды. Бұл индекстелу барысында Clarivate Analytics компаниясы журналды одан әрі the Science Citation Index Expanded, the Social Sciences Citation Index және the Arts & Humanities Citation Index-ке қабылдау мәселесін қарастыруда. Web of Science зерттеушілер, авторлар, баспашылар мен мекемелерге контент тереңдігі мен сапасын ұсынады. ҚР ҰҒА Хабарлары. Химия және технология сериясы Emerging Sources Citation Index-ке енуі біздің қоғамдастық үшін ең өзекті және беделді химиялық ғылымдар бойынша контентке адалдығымызды білдіреді.

НАН РК сообщает, что научный журнал «Известия НАН РК. Серия химии и технологий» был принят для индексирования в Emerging Sources Citation Index, обновленной версии Web of Science. Содержание в этом индексировании находится в стадии рассмотрения компанией Clarivate Analytics для дальнейшего принятия журнала в the Science Citation Index Expanded, the Social Sciences Citation Index и the Arts & Humanities Citation Index. Web of Science предлагает качество и глубину контента для исследователей, авторов, издателей и учреждений. Включение Известия НАН РК в Emerging Sources Citation Index демонстрирует нашу приверженность к наиболее актуальному и влиятельному контенту по химическим наукам для нашего сообщества.

Б а с р е д а к т о р ы
х.ғ.д., проф., ҚР ҰҒА академигі
М.Ж. Жұрынов

Р е д а к ц и я а л қ а с ы:

Ағабеков В.Е. проф., академик (Белорус)
Башов А.Б. проф., академик (Қазақстан)
Бүркітбаев М.М. проф., академик (Қазақстан)
Волков С.В. проф., академик (Украина)
Воротынцев М.А. проф., академик (Ресей)
Газалиев А.М. проф., академик (Қазақстан)
Джусипбеков У.Ж. проф., корр.-мүшесі (Қазақстан)
Жармағамбетова А.К. проф. (Қазақстан), бас ред. орынбасары
Жоробекова Ш.Ж. проф., академик (Қырғыстан)
Иткулова Ш.С. проф. (Қазақстан)
Манташян А.А. проф., академик (Армения)
Пралиев К.Д. проф., академик (Қазақстан)
Рахимов К.Д. проф., академик (Қазақстан)
Рудик В. проф., академик (Молдова)
Стрельцов Е. проф. (Белорус)
Тельтаев Б.Б. проф., академик (Қазақстан)
Тодераш И. проф., академик (Молдова)
Тулеуов Б.И. проф., академик (Қазақстан)
Фазылов С.Д. проф., академик (Қазақстан)
Фарзалиев В. проф., академик (Әзірбайжан)
Халиков Д.Х. проф., академик (Тәжікстан)
Шайхутдинов Е.М. проф., академик (Қазақстан)

«ҚР ҰҒА Хабарлары. Химия және технология сериясы».

ISSN 2518-1491 (Online),

ISSN 2224-5286 (Print)

Меншіктенуші: «Қазақстан Республикасының Ұлттық ғылым академиясы» Республикалық қоғамдық бірлестігі (Алматы қ.).

Қазақстан Республикасының Ақпарат және қоғамдық даму министрлігінің Ақпарат комитетінде 29.07.2020 ж. берілген № KZ66VPY00025419 мерзімдік басылым тіркеуіне қойылу туралы куәлік.

Тақырыптық бағыты: *химия және жаңа материалдар технологиясы саласындағы басым ғылыми зерттеулерді жариялау.*

Мерзімділігі: жылына 6 рет.

Тиражы: 300 дана.

Редакцияның мекенжайы: 050010, Алматы қ., Шевченко көш., 28; 219, 220 бөл.; тел.: 272-13-19; 272-13-18,
<http://chemistry-technology.kz/index.php/en/arhiv>

© Қазақстан Республикасының Ұлттық ғылым академиясы, 2020

Редакцияның мекенжайы: 050100, Алматы қ., Қонаев к-сі, 142, «Д. В. Сокольский атындағы отын, катализ және электрохимия институты» АҚ, каб. 310, тел. 291-62-80, факс 291-57-22, e-mail:orgcat@nursat.kz

Типографияның мекенжайы: «NurNaz GRACE», Алматы қ., Рысқұлов көш., 103.

Главный редактор
д.х.н., проф., академик НАН РК
М.Ж. Журинов

Редакционная коллегия:

Агабеков В.Е. проф., академик (Беларусь)
Баешов А.Б. проф., академик (Казахстан)
Буркитбаев М.М. проф., академик (Казахстан)
Волков С.В. проф., академик (Украина)
Воротынцев М.А. проф., академик (Россия)
Газалиев А.М. проф., академик (Казахстан)
Джусипбеков У.Ж. проф., чл.-корр. (Казахстан)
Жармагамбетова А.К. проф. (Казахстан), зам. гл. ред.
Жоробекова Ш.Ж. проф., академик (Кыргызстан)
Иткулова Ш.С. проф. (Казахстан)
Мангашян А.А. проф., академик (Армения)
Пралиев К.Д. проф., академик (Казахстан)
Рахимов К.Д. проф., академик (Казахстан)
Рудик В. проф., академик (Молдова)
Стрельцов Е. проф. (Беларусь)
Тельтаев Б.Б. проф., академик (Казахстан)
Тодераш И. проф., академик (Молдова)
Тулеев Б.И. проф., академик (Казахстан)
Фазылов С.Д. проф., академик (Казахстан)
Фарзалиев В. проф., академик (Азербайджан)
Халиков Д.Х. проф., академик (Таджикистан)
Шайхутдинов Е.М. проф., академик (Казахстан)

«Известия НАН РК. Серия химии и технологий».

ISSN 2518-1491 (Online),

ISSN 2224-5286 (Print)

Собственник: Республиканское общественное объединение «Национальная академия наук Республики Казахстан» (г. Алматы).

Свидетельство о постановке на учет периодического печатного издания в Комитете информации Министерства информации и общественного развития Республики Казахстан № KZ66VPY00025419, выданное 29.07.2020 г.

Тематическая направленность: *публикация приоритетных научных исследований в области химии и технологий новых материалов.*

Периодичность: 6 раз в год.

Тираж: 300 экземпляров.

Адрес редакции: 050010, г. Алматы, ул. Шевченко, 28; ком. 219, 220; тел. 272-13-19; 272-13-18,

<http://chemistry-technology.kz/index.php/en/arhiv>

© Национальная академия наук Республики Казахстан, 2020

Адрес редакции: 050100, г. Алматы, ул. Кунаева, 142, АО «Институт топлива, катализа и электрохимии им. Д.В. Сокольского», каб. 310, тел. 291-62-80, факс 291-57-22, e-mail: orgcat@nursat.kz

Адрес типографии: «NurNaz GRACE», г. Алматы, ул. Рыскулова, 103.

Editor in chief

doctor of chemistry, professor, academician of NAS RK

M.Zh. Zhurinov

Editorial board:

Agabekov V.Ye. prof., academician (Belarus)
Bayeshov A.B. prof., academician (Kazakhstan)
Burkitbayev M.M. prof., academician (Kazakhstan)
Volkov S.V. prof., academician (Ukraine)
Vorotyntsev M.A. prof., academician (Russia)
Gazaliyev A.M. prof., academician (Kazakhstan)
Dzhusipbekov U.Zh. prof., corr. member (Kazakhstan)
Zharmagambetova A.K. prof. (Kazakhstan), deputy editor in chief
Zhorobekova Sh.Zh. prof., academician (Kyrgyzstan)
Itkulova Sh.S. prof. (Kazakhstan)
Mantashyan A.A. prof., academician (Armenia)
Praliyev K.D. prof., academician (Kazakhstan)
Rakhimov K.D. prof., academician (Kazakhstan)
Rudik V. prof., academician (Moldova)
Streltsov Ye. prof. (Belarus)
Teltaev B.B. prof., akademik (Kazakhstan)
Toderash I. prof., academician (Moldova)
Tuleuov B.I. prof., akademik (Kazakhstan)
Fazylov S.D. prof., akademik (Kazakhstan)
Farzaliyev V. prof., academician (Azerbaijan)
Khalikov D.Kh. prof., academician (Tadjikistan)
Shaihutdinov E.M. prof., akademik (Kazakhstan)

News of the National Academy of Sciences of the Republic of Kazakhstan. Series of chemistry and technology.

ISSN 2518-1491 (Online),

ISSN 2224-5286 (Print)

Owner: RPA "National Academy of Sciences of the Republic of Kazakhstan" (Almaty).

The certificate of registration of a periodical printed publication in the Committee of information of the Ministry of Information and Social Development of the Republic of Kazakhstan No. **KZ66VPY00025419**, issued 29.07.2020.

Thematic scope: *publication of priority research in the field of chemistry and technology of new materials*

Periodicity: 6 times a year.

Circulation: 300 copies.

Editorial address: 28, Shevchenko str., of. 219, 220, Almaty, 050010, tel. 272-13-19; 272-13-18,

<http://chemistry-technology.kz/index.php/en/arhiv>

© National Academy of Sciences of the Republic of Kazakhstan, 2020

Editorial address: JSC «D.V. Sokolsky institute of fuel, catalysis and electrochemistry», 142, Kunayev str., of. 310, Almaty, 050100, tel. 291-62-80, fax 291-57-22, e-mail: orgcat@nursat.kz

Address of printing house: «NurNaz GRACE», 103, Ryskulov str, Almaty.

NEWS

OF THE NATIONAL ACADEMY OF SCIENCES OF THE REPUBLIC OF KAZAKHSTAN

SERIES CHEMISTRY AND TECHNOLOGY

ISSN 2224-5286

<https://doi.org/10.32014/2020.2518-1491.101>

Volume 6, Number 444 (2020), 79 – 86

UDC 665.666.42

F. R. Ismagilov¹, S. M. Akhmetov², M. K. Jexenov³, M. Диаров²

¹Astrakhan State Technical University, Astrakhan, Russia;

²Atyrau University of Oil and Gas named after S. Utebaev, Atyrau, Kazakhstan;

³LLP "Emba petroleum Project", Atyrau, Kazakhstan.

E-mail: frismagilov@bk.ru, axmetov_aing@mail.ru, ddm85@mail.ru, muftah.diarov@mail.ru

METHOD FOR ADSORPTION PURIFICATION OF ASSOCIATED OIL GASES FROM MERCAPTANS

Abstract. The paper examines methods of utilization of zeolite regeneration gases to assess the possibility of using them in an industrial adsorption unit for drying and purifying gases from hydrogen sulfide and mercaptans. The most promising is the method of decomposition of mercaptans to hydrogen sulfide and hydrogen on solid catalysts, which is carried out at a pressure and temperature of 200-350 °C, as well as the method of direct gas-phase catalytic oxidation of mercaptans with atmospheric oxygen. We carried out experiments on the purification of zeolite regeneration gases of the Orenburg GPP by oxidation with atmospheric oxygen using an iron oxide catalyst at a temperature of 180-250 °C. They showed that the gas purified from mercaptans contained elemental sulfur and disulfides as the main oxidation products, and 0.2% vol. of sulfur dioxide was present as a by-product. The method of purification from mercaptans and heavy hydrocarbon gases regeneration of composite adsorbent by thermocatalytic oxidation is also proposed. To reduce the yield of undesirable sulfur dioxide in the regeneration gas purified from mercaptans, it is proposed to divide the regeneration gas stream into two streams, while the larger part, comprising about 80-90% vol., is sent to oxidation on a zinc-iron catalyst at 200 °C, the second stream is mixed with oxidation products in a volume ratio in terms of mercaptans and sulfur dioxide equal to 1.5-2.2÷1, respectively, then the resulting mixture is passed at 160-200 °C through a titanium oxide catalyst with a gas volumetric velocity of 4000-6000 h⁻¹. The proposed scheme for gas purification from mercaptans and heavy hydrocarbons on a composite adsorbent with oxidative regeneration makes it possible to carry out the subsequent process of amine purification of gas from hydrogen sulfide without the complications associated with foaming of the working solution. Furthermore, it becomes possible to transport gas purified from mercaptans and hydrogen sulfide through the pipeline without precipitation of condensate.

Keywords: adsorption; gas purification; associated gas; mercaptans; hydrogen sulfide; regeneration gases; thermocatalytic decomposition; oxidation; sulfur; disulfides; recirculation gases.

The relevance of the topic. Adsorption treatment using aluminosilicates is widely used in the gas and petrochemical industry for drying and purifying natural gases from mercaptans. The process of drying and purification of natural gas from sulfur compounds is carried out in an adsorber system, which is filled with zeolites and work alternately at the stages of adsorption of impurities from raw materials, regeneration, and cooling of zeolites. During the adsorption treatment of gas, impurities such as water, hydrogen sulfide, mercaptans pass into the primary porous structure of the adsorbent. When the adsorbent is saturated with extracted impurities, its high-temperature regeneration is performed by a gas stream, into which previously extracted impurities pass [1]. The degree of gas adsorption treatment and its economic efficiency largely depends on the technology of adsorbent regeneration, the choice of regeneration gases

(i.e. desorbing gas), and the method of their utilization (i.e. gases of desorption or regeneration) of adsorbents. In addition to mercaptans, hydrogen sulfide and water vapors, carbon dioxide, and sulfur compounds from the source gas are concentrated there.

Thus, current research projects are aimed at developing methods for adsorption purification of associated petroleum gases from mercaptans.

Discussion of problems. Regeneration of the adsorbent of the drying process and purification of natural gas from sulfur compounds is carried out by heating the layer by purging the gas heated up to 320-380 °C through it. Moreover, as the regeneration gas, one can use 17-23% of raw gas that is delivered for drying and purification [2]. In industry as regeneration gas and cooler for zeolite, a natural gas adsorption drying unit usually uses 5-15% of gas (in terms of crude gas), which is supplied for drying and purification, and drained and purified from sulfur compounds [3]. It is possible to achieve deep regeneration of zeolite when the adsorbent is purged with a methane fraction extracted from a part of the natural gas, which is drained and purified from sulfur compounds and mixed with the nitrogen-methane fraction. This fraction is a waste of the helium concentrate production that ensures the calorific value of the fraction mixture to be no lower than 7600 kcal/m³ at the corresponding ratio [4]. Also, there is a well-known method of zeolite regeneration, which is applied for the drying and purifying of natural gas, where a methane fraction is used to purge the regenerated CaA zeolite [5].

A common disadvantage of the above-mentioned methods of zeolite regeneration at units of drying and purification of hydrocarbon gases is that adsorbent regeneration gases are obtained when using as a desorbing agent of hydrocarbon gases (methane fraction or part of the purified source hydrocarbon gas). Later, those adsorbent regeneration gases are used as fuel that is contaminated with the same sulfur-containing substances as the initial purified hydrocarbon gas. The purpose of the adsorption process is to concentrate sulfur-containing and other undesirable impurities of the source gas (then used as fuel) in its part, which is then also used as fuel for the needs of the enterprise. It pollutes the industrial zone instead of distribution in the environment by numerous consumers in the absence of purification of the hydrocarbon fuel gas. The process of adsorption treatment without the utilization of regeneration gases does not reduce the amount of sulfur oxide release into the atmosphere. Furthermore, the burning of valuable sulfur-containing substances leads to their irretrievable loss to the economy. The validity of extracting and processing of sulfur-containing substances present in zeolite regeneration gases is of ecological and economic importance.

Materials and methods of research. The production conditions where the adsorption installation operates, the composition of the purified gas, nature, and concentration of sulfur compounds, which are present in it, largely influence the choice of a rational method of utilization of zeolite regeneration gases or other adsorbents used in the drying processes and purification of the gas from sulfur compounds. The following three thermocatalytic methods are the most promising for gas processing plants (GPP). The first of them is based on the reaction of decomposition of mercaptans to hydrogen sulfide and hydrogen on solid catalysts, which is carried out at a pressure and temperature (200-350 °C) of the adsorbent regeneration [6-12]. The practical implementation of this method at GPP is facilitated by the availability of energy at the plant for further purification of regeneration gas from hydrogen sulfide formed during the decomposition of mercaptans, and its utilization by the Claus process. In addition to hydrogen sulfide, thermocatalytic decomposition of mercaptans is accompanied by the production of saturated and unsaturated hydrocarbons, and parallel reactions of the destruction of amines, methanol, and other impurities contained in the zeolite desorption gas [13-15].

The third method is more attractive, and that is direct thermocatalytic gas-phase oxidation of mercaptans to sulfur by atmospheric oxygen. We carried out experiments on the purification of zeolite regeneration gases of the Orenburg GPP by oxidation with atmospheric oxygen using an iron oxide catalyst at a temperature of 180-250 °C. They showed that the gas purified from mercaptans contained elemental sulfur and disulfides as the main oxidation products, and 0.2% vol. of sulfur dioxide was present as a by-product [16-17]. In these experiments, it was found that hydrogen sulfide and other sulfur-containing compounds (carbonyl sulfide, carbon disulfide, sulfides), which are contained in small amounts in zeolite regeneration gases, are also subjected to oxidation, and the product of their oxidation is elemental sulfur. Most of the sulfur-containing oxidation products can be separated from the reaction gas by condensation when cooled to ambient temperature, which greatly simplifies the process.

One of the crucial processes for purification of zeolite regeneration gases is alkaline-free direct oxidation of mercaptans based on the conversion of H_2S and mercaptans to non-toxic forms (di- and polysulfides) by atmospheric oxygen directly in hydrocarbon media [18]. Oxidation reactions occurring in hydrocarbon raw materials are significantly accelerated in the presence of metal-complex catalysts based on transition metals [19-22]. This technology eliminates the stage of alkaline extraction and, consequently, the need for disposal of toxic sulfur-alkaline effluents. The effectiveness of such catalytic systems was established in the laboratory conditions on model mixtures of thiols and hydrocarbons, for example, which is shown in [18].

Most of the works of Kazakh scientists are devoted to the purification of oil gases.

The authors of the following work conducted research on the use of liquefied petroleum gas as a raw material for the production of liquid oxygen-containing organic compounds [23].

Research results. This article describes a method for purification of composite adsorbent regeneration gas, which, in contrast to aluminosilicate sorbents, can absorb not only mercaptans but heavy hydrocarbons contained in associated petroleum gas or processing gases of light hydrocarbon raw materials. The composite adsorbent is porous coal or natural sorbent impregnated with a moisture-absorbing substance, which has a high dynamic capacity for water [24]. During the development of the technology of gas regeneration of composite adsorbent by direct oxidation, a few new technical solutions were found that ensured the achievement of the following positive result [25]:

1) simplification of the catalytic stage by conducting the process in a single stage and lack of need for precise control of the ratio of components in the catalytic oxidation of mercaptans;

2) increase of purification degree of hydrocarbon gases by removing, along with mercaptans, both heavy hydrocarbons, and volatile oxidation products and sulfur vapors when gas purification on composite adsorbents is applied;

3) reduction of the energy consumption of the process due to the use of pre-concentration of mercaptans on composite adsorbents;

4) reduced material consumption by decreasing the volume of the catalytic oxidation reactor and loading the catalyst while decreasing the volume flow of the purified gas.

Figure 1 illustrates the scheme of a hydrocarbon gas treatment installation on a composite adsorbent with the utilization of regeneration gases by direct oxidation and recirculation into the stream of purified gas.

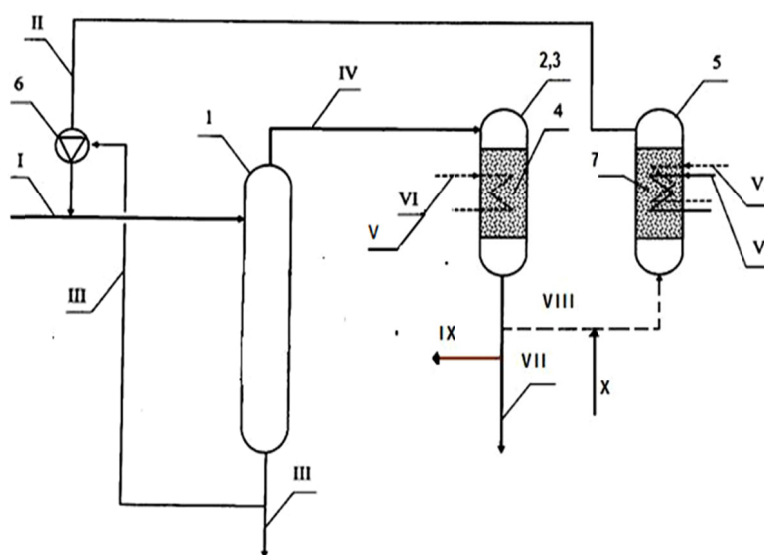

Figure 1 - The scheme of a hydrocarbon gas treatment installation on a composite adsorbent with the utilization of regeneration gases:

Flows: I – purified gas; II – oxidation products; III – liquid oxidation products; IV – separation gas; V – air-coolant; VI – air-refrigerant; VII – gas purified from mercaptans; VIII – regeneration gas; IX – purge gas; X – process air.

Devices: 1 - gas separator; 2,3 - adsorbents; 4 - composite adsorbent;

5 - oxidation reactor; 6 - liquid-ring pump; 7 - catalyst

According to this technology, the hydrocarbon gas is pre-mixed with the oxidation products, and the mixture is separated with the release of liquid oxidation products and separation gas. This gas is subjected to adsorption treatment on a composite adsorbent, using as porous coal, for example, the Sibunit brand, while indirectly cooling the adsorbent to the adsorption temperature, which should not be lower than the freezing point of water or hydrate formation. The adsorbent regeneration is carried out by blowing off the purified gas at low pressure and indirect heating the adsorbent with coolant to the regeneration temperature, and the regenerated adsorbent is cooled indirectly with a refrigerant to the adsorption temperature.

After that, the regeneration gas is mixed with air at a mass ratio of mercaptans to atmospheric oxygen equal to $2.2\div 3:1$, which is higher than the stoichiometric ratio equal to $2:1$, and it is passed through the oxidation catalyst at the volume rate and oxidation temperature. The oxidation products are recirculated into the purified gas stream, compressed to the pressure of the hydrocarbon gas utilizing a liquid-ring pump using the liquid oxidation products as the working fluid. In this case, for example, atmospheric air can be used as a refrigerant, and the coolant can be atmospheric air heated with a catalytic air heater by direct mixing of the oxidation products of hydrocarbon condensate or dry gas with atmospheric air.

Pre-mixing of hydrocarbon gas with oxidation products and separation of the mixture with the release of liquid oxidation products and separation gas allows to remove the liquid products of the oxidative conversion of mercaptans from the process, to obtain a working fluid for a liquid-ring pump that recirculates the regeneration gas, as well as to recirculate the non-reacting mercaptans for re-oxidation. This prevents contamination of the adsorbent and increases its lifetime.

The purification of hydrocarbon gas from mercaptans, heavy hydrocarbons, volatile oxidation products, and sulfur fumes is possible thanks to adsorption treatment of separation gas using carbonaceous adsorbent at simultaneous indirect cooling of the adsorbent to the adsorption temperature, but not below the freezing point of water or hydrate formation. It is achieved through making the most favorable conditions for adsorption with a maximum dynamic capacity of the adsorbent, preventing its heating because of the heat release of adsorption. This reduces the adsorbent load and the metal content of the equipment.

Regeneration of the adsorbent by blowing off the purified gas at low pressure and simultaneous indirect heating the adsorbent with coolant to the regeneration temperature ($200\text{ }^{\circ}\text{C}$) allows for deep regeneration of the adsorbent with minimal purge gas consumption. The optimal regeneration temperature depends on the chemical composition of purified gas and the type of adsorbent, the desired degree of purification of hydrocarbon gas from mercaptans, and heavy hydrocarbons (desired dew point by hydrocarbons), energy costs, etc.

The optimal flow rate of the purified gas for the regeneration of the adsorbent depends on the chemical composition of the gas being treated, the type of adsorbent, as well as the condition of the thermal balance of the mercaptan oxidation stage. When the concentration of mercaptans in the regeneration gas is high, the purified gas consumption for regeneration is increased to keep the temperature during the oxidation stage below the permissible level and to ensure the selectivity of the oxidation of mercaptans to disulfides and sulfur without the formation of sulfur dioxide. As the concentration of mercaptans in the regeneration gas decreases, the consumption of the purified gas for regeneration is reduced, and, if necessary, indirect heating of the catalyst with coolant is additionally performed to maintain the oxidation temperature.

The usage of indirect heating of the adsorbent by coolant to regeneration temperature in the regeneration stage and the indirect cooling of the regenerated adsorbent by the refrigerant to the adsorption temperature allows to control the temperature of the adsorbent and reduce the total duration of the regeneration stage and adsorption cycle, as well as to reduce the load of the adsorbent and metal content of equipment.

Oxidation of mercaptans present in the regeneration gas in a mixture with air has a mass ratio of mercaptans to atmospheric oxygen equal to $2.2\div 3:1$, which is higher than the stoichiometric ratio for the oxidation reaction to sulfur and disulfides, and it prevents the formation of sulfur dioxide, which can potentially contaminate the purified gas during a slip in the adsorber. A raise in the mass ratio of mercaptans to atmospheric oxygen higher than $3:1$ leads to an increase in the recirculation of non-reacted mercaptans and an overload of the adsorbent. When the mass ratio of mercaptans to atmospheric oxygen becomes lower than $2.2:1$, it leads to the formation of sulfur dioxide in the oxidation products, which

pollutes the purified gas. The experiments have shown that the optimal temperature and volume rate of oxidation depend on the type of catalyst.

The loss of hydrocarbon gas with the regeneration gas is prevented by recirculation of the oxidation products into the purified gas stream compressing it to the pressure of hydrocarbon gas. This is achieved by utilizing a liquid-ring pump that uses liquid oxidation products as the working fluid. Besides, it becomes possible to conduct regeneration at a reduced pressure of up to 5-15 kPa, which is determined by the characteristics of the pump and the initial pressure of the gas being treated. During compression, the oxidation products are cooled due to the contact of the gas with the working fluid, the liquid oxidation products are condensed, and most of the mercaptans contained in the hydrocarbon gas are absorbed. These processes take place without the use of additional cooling and separation equipment. As a result, the load of the adsorbent and the material consumption of the process can be reduced, whereas the degree of purification of hydrocarbon gas can be increased.

For example, the use of atmospheric air as a refrigerant and, as a coolant, atmospheric air heated with a catalytic air heater by direct mixing of the oxidation products of a hydrocarbon fuel with atmospheric air, allows providing effective heating and cooling of the adsorbent with the minimal technological difficulties.

The use of a catalytic air heater instead of a conventional fire furnace reduces the cost of equipment, the fire and explosion hazard of the installation and increases the reliability of its operation, as well as reduces the release of nitrogen oxides and carbon monoxide into the atmosphere due to controlled flameless combustion (oxidation) of gaseous or liquid distillate fuel at temperatures below 900 °C.

The efficiency of the described purification method of associated petroleum gas and regeneration gas is shown by the data of the following experiment at the pilot installation. The composition of the gas supplied for treatment, vol.% is oxygen 0.03, nitrogen 10.90, carbon dioxide 0.28, methane 70.10, ethane 5.61, propane 4.02, n-butane 2.65, isobutane 1.14, isopentane 1.35, pentane and higher 2.06, hydrogen sulfide 1.64, mercaptans 0.24. Chromatographic analysis reveals the absence of mercaptans in the purified gas, the content of other components is oxygen 0.13, nitrogen 11.66, carbon dioxide 0.29, methane 71.7, ethane 5.73, propane 4.10, n-butane 2.40, isobutane 1.12, isopentane 1.18, and pentane and higher hydrocarbons are absent.

Conclusions. Thus, the lack of heavy hydrocarbons in gas purified from mercaptans on composite adsorbent enables a subsequent process of its amine purification from hydrogen sulfide without the complications associated with the foaming of the working solution. Furthermore, it becomes possible to transport gas purified from mercaptans and hydrogen sulfide through the pipeline without precipitation of condensate.

Ф. Р. Исмагилов¹, С. М. Ахметов², М. К. Джексенов³, М. Диаров²

¹Астрахань мемлекеттік техникалық университеті, Астрахань, Ресей;

²С.Өтебаев атындағы Атырау мұнай және газ университеті, Атырау, Қазақстан;

³«Emba Petroleum Project» ЖШС, Атырау, Қазақстан

ІЛЕСПЕ МҰНАЙ ГАЗЫН МЕРКАПТАННАН АДСОРБЦИЯЛЫҚ ТАЗАРТУДЫҢ ТӘСІЛІ

Аннотация. Цеолиттер регенерация газын кәдеге жарату әдістеріне оларды кептіру және газды күкіртті сутегі мен меркаптаннан тазартудың өнеркәсіптік адсорбциялық кондырғысында пайдалану мүмкіндігін бағалау үшін талдау жүргізілді.

Жұмыста композитті адсорбент регенерация газын тазарту әдісі сипатталған, оның алюмосиликатты сорбенттерден негізгі айырмашылығы – меркаптанмен қатар жеңіл көмірсутекті шикізатты қайта өңдеу газында немесе ілеспе мұнай газының құрамында кездесетін ауыр көмірсутектерді де сіңіру мүмкіндігі бар.

Тікелей тотығу әдісімен композиттік адсорбентті регенерациялау газын алу технологиясын әзірлеудің негізінде бірнеше оң нәтижеге қол жеткізуді қамтамасыз ететін бірқатар жаңа техникалық шешімдер ұсынылды, атап айтқанда:

– процесті жүргізуді бір саты шеңберінде өткізу және және меркаптаннардың каталитикалық тотығуы кезінде компоненттердің арақатынасын дәл реттеу қажеттілігінің болмауы есебінен каталитикалық кезеңді анағұрлым қарапайым түрге айналдыру;

– меркаптандармен қатар, ауыр көмірсутектерді де және сонымен қатар тотығудың ұшпа өнімі мен күкірт буын өшіру және композиттік адсорбенттерде газ тазартуды қолдану арқылы газ тазарту деңгейін арттыру;

– композиттік адсорбенттерге меркаптанды алдын ала шоғырландыруды қолдану есебінен процестің энергия сыйымдылығын азайту;

– тотығу каталикалық реакторының көлемін және тазартылатын газдың көлемдік шығынын азайту кезінде катализаторды қолдану есебінен материалдық сыйымдылықты төмендету.

Неғұрлым перспективті деп қысым мен 200-350 °С температура аралығында жүргізілетін меркаптанды күкіртті сутегі мен сутегіне дейінгі қатты катализаторда ыдырату әдісін, сондай-ақ, меркаптанның ауа оттегімен тікелей газофазды каталикалық тотығу әдісін айтуға болады. 180-250°С температурада теміроксидті катализаторда ауаны оттегімен тотықтыру арқылы Орынбор ГӨЗ цеолиттерін регенерациялау газын тазарту бойынша жүргізген тәжірибеміз меркаптандардан тазартылған газда негізгі тотығу өнімдері ретінде қарапайым күкірт пен дисульфидтердің болатын-дығын, ал күкірттің қос тотығы жанама өнімінің мөлшері 0,2% деңгейде екендігін көрсетті. Сонымен қатар, меркаптан мен ауыр көмірсутектерден композиттік адсорбент регенерациясын меркаптандарды термокаталикалық тотығу әдісімен күкіртке дейін ауа оттегімен тазарту әдісі ұсынылды.

Меркаптаннан тазартылған регенерация газында күкірттің қос тотығының шығымын азайту үшін регенерация газының ағынын екі ағынға бөлу ұсынылды, осыған орай көлемнің шамамен 80-90% құрайтын үлкен бөлігі 200°С кезінде темірхромцинка катализаторына тотығуға жіберіледі, ал екінші ағын тотығу өнімдерімен меркаптан мен күкірттің қос тотығына шаққанда 1,5-2,2÷1 тең сәйкес көлемдік қатынаста араластырылады және алынған қоспаны газдың көлемдік жылдамдығы 4000-6000 сағ⁻¹ құрайтын титан-тотықты катализатор арқылы 160-200°С кезінде өткізеді.

Тотығу регенерациясы бар композиттік адсорбентте меркаптан мен ауыр көмірсутектен газ тазартудың ұсынылған схемасы газды аминді күкіртті сутегіден тазартудың келесі процесін жұмыс ерiтiндiсiнiң көбіктенуіне байланысты туындайтын қиындықтың алдын ала жүргізуге және меркаптан мен күкіртсутектен тазартылған регенерация газын конденсат түспестен құбыр арқылы тасымалдауды жүзеге асыруға мүмкіндік береді.

Суытқыш агент ретінде, мысалы, атмосфералық ауаны, ал жылу тасығыш ретінде ауаның каталикалық жылытқышы арқылы көмірсутекті отынның атмосфералық ауамен тотығу өнімін тікелей араластыру негізінде қыздырылған атмосфералық ауаны пайдалану, адсорбентті тиімді жылыту мен салқындату үрдісінің технологиялық күрделілігін жеңілдетуге мүмкіндік береді.

Әдетте қолданылатын отпен қыздыру пешінің орнына ауаның каталикалық қыздырғышын пайдалану қолданылатын жабдық құнын азайтуға, қондырғының өрт пен жарылыс қауіптілігін азайтуға және жұмысының сенімділігін арттыруға, сондай-ақ 900°С төмен температурада газ тәрізді немесе сұйық дистиллятты отынның бақыланатын жалынсыз жағу (тотығу) есебінен атмосфераға азот және көміртегі тотығының шығарындысын қысқартуға мүмкіндік береді.

Түйін сөздер: адсорбция, газ тазарту, ілеспе газ, меркаптан, күкіртсутек, регенерация газы, термокаталикалық ыдырау, тотығу, күкірт, дисульфидтер, рециркуляция гадары.

Ф. Р. Исмагилов¹, С. М. Ахметов², М. К. Джексенов³, М. Диаров²

¹Астраханский государственный технический университет, Астрахань, Россия;

²Атырауский университет нефти и газа им. С. Утебаева, Атырау, Казахстан;

³ТОО «Emba Petroleum Progect», Атырау, Казахстан

СПОСОБ АДСОРБЦИОННОЙ ОЧИСТКИ ПОПУТНЫХ НЕФТЯНЫХ ГАЗОВ ОТ МЕРКАПТАНОВ

Аннотация. Проведен анализ методов утилизации газов регенерации цеолитов для оценки возможности использования их на промышленной адсорбционной установке осушки и очистки газа от сероводорода и меркаптанов.

В работе описан метод очистки газов регенерации композитного адсорбента, который, в отличие от алюмосиликатных сорбентов обладает возможностью поглощения наряду с меркаптанами и тяжелых углеводородов, содержащихся в попутном нефтяном газе или в газах переработки легкого углеводородного сырья.

Разработкой технологии получения газов регенерации композитного адсорбента методом прямого окисления найдены ряд новых технических решений, обеспечивающих достижение нескольких положительных результатов, а именно:

- упрощение каталитической стадии за счет проведения процесса в одну стадию и отсутствия необходимости точного регулирования соотношения компонентов при каталитическом окислении меркаптанов;
- повышение степени очистки углеводородных газов за счет удаления наряду с меркаптанами, как тяжелых углеводородов, так и летучих продуктов окисления и паров серы, путем применения очистки газов на композитных адсорбентах;
- уменьшение энергоемкости процесса за счет применения предварительного концентрирования меркаптанов на композитных адсорбентах;
- снижение материалоемкости за счет уменьшения объема каталитического реактора окисления и загрузки катализатора при уменьшении объемного расхода очищаемого газа.

Наиболее перспективными являются метод разложения меркаптанов до сероводорода и водорода на твердых катализаторах, который проводится при давлении и температуре 200–350 °С, а также метод прямого газофазного каталитического окисления меркаптанов кислородом воздуха. Опыты, проведенные нами по очистке газов регенерации цеолитов Оренбургского ГПЗ путем окисления кислородом воздуха на железоксидном катализаторе при температуре 180–250 °С показали, что в очищенном от меркаптанов газе в качестве основных продуктов окисления присутствуют элементарная сера и дисульфиды, а содержание побочного продукта двуокиси серы находится на уровне 0,2% об. Предложен также метод очистки от меркаптанов и тяжелых углеводородов газов регенерации композитного адсорбента методом термокаталитического окисления меркаптанов до серы кислородом воздуха.

Для снижения выхода нежелательной двуокиси серы в очищенном от меркаптанов газе регенерации предложено поток газа регенерации делить на два потока, при этом большая по объему часть, составляющая примерно 80–90 % об., направляют на окисление на железохромциновом катализаторе при 200 °С, а второй поток смешивают с продуктами окисления в объемном соотношении в пересчете на меркаптаны и двуокись серы, равном 1,5–2,2±1, соответственно, и полученную смесь пропускают при 160–200 °С через титаноксидный катализатор при объемной скорости газа 4000–6000 ч⁻¹.

Предложенная схема очистки газов от меркаптанов и тяжелых углеводородов на композитном адсорбенте с окислительной регенерацией дает возможность вести последующий процесс аминовой очистки газа от сероводорода без осложнения, связанного с вспениванием рабочего раствора, и осуществлять транспортировку очищенного от меркаптанов и сероводорода газа регенерации по трубопроводу без выпадения конденсата.

Использование в качестве хладагента, например, атмосферного воздуха, а в качестве теплоносителя - атмосферного воздуха, нагретого с помощью каталитического нагревателя воздуха прямым смешением продуктов окисления углеводородного топлива с атмосферным воздухом, позволяет с наименьшими технологическими сложностями обеспечить эффективный нагрев и охлаждение адсорбента.

Использование каталитического нагревателя воздуха вместо обычно применяемой печи огневого нагрева позволяет снизить стоимость оборудования, уменьшить пожаро- и взрывоопасность установки и повысить надежность его работы, а также сократить выбросы окислов азота и окиси углерода в атмосферу за счет контролируемого беспламенного сжигания (окисления) газообразного или жидкого дистиллятного топлива при температуре ниже 900 °С.

Ключевые слова: адсорбция; очистка газов; попутный газ; меркаптаны; сероводород; газы регенерации; термокаталитическое разложение; окисление; сера; дисульфиды; газы рециркуляции.

Information about authors:

Ismagilov F.R., Doctor of Technical Sciences, Professor of the Department of Chemical Technology of oil and gas processing of Astrakhan state technical University; Astrakhan, Russia, E-mail: frismagilov@bk.ru; <https://orcid.org/0000-0002-1577-8929>;

Akhmetov S.M., Doctor of Technical Sciences, Professor, Vice-rector for science and innovation of Atyrau University of oil and gas named after S. Utebayev, Academician of the National Engineering Academy of the Republic of Kazakhstan, Academician of the Russian Academy of Natural Sciences; Atyrau, Republic of Kazakhstan; E-mail: axmetov_aing@mail.ru; <https://orcid.org/0000-0002-1983-457X>;

Jexenov M.K. Candidate of Engineering Sciences, chief specialist LLP "Emba petroleum Project", Atyrau, Republic of Kazakhstan; E-mail: ddm85@mail.ru; <https://orcid.org/0000-0002-1741-3931>;

Diarov M., Doctor of Geological and Mineralogical Sciences, Professor, Chief researcher Of the scientific laboratory "Geoecology" of Atyrau University of oil and gas named after S. Utebayev, Academician of the National Academy of Sciences of the Republic of Kazakhstan; Atyrau, Republic of Kazakhstan; muftah.diarov@mail.ru; <https://orcid.org/0000-0002-4799-5821>

REFERENCES

- [1] Afanasiev A.I., Bekirov T.M., Barsuk S.D. (2002). Technology of processing of natural gas and condensate: Handbook. (ISBN 5-8365-0107-6). Moscow. Nedra. P. 120-121 (in Russ.).
- [2] Encyclopedia of the gas industry. 4th ed. Translated from French. Edited by Basniev K.S.. (1994). (ISBN: 5-2-III-9-(03)). Moscow. JSC TWANT. 884 p. (in Russ.).
- [3] Nikolaev V.V., Busygina N.V., Busygin I.G. (1998). Basic processes of physical and physical-chemical gas processing. (5-247-03813-4). Nedra. 134 p. (in Russ.).
- [4] Shakhov A.D., Ivanov S. I., Stolypin V. I. et al. (2003). Method of zeolite regeneration of the process of drying and purification of natural gas from sulfur compounds. RU patent 2240176. (in Russ.).
- [5] Nikolaev V. V., Gafarov N. A., Lomovskikh V. D., et al. (2000). Method of zeolite regeneration of the process of drying and purification of natural gas from sulfur compounds. RU patent 2159663. (in Russ.).
- [6] Vildanov A.F., Rafikov L.A., Korobkov F.A. et al. (2016). Thermocatalytic treatment of zeolite regeneration gases from mercaptans. Technology of oil and gas. N. 6. P.3. (in Russ.).
- [7] Reina M., Martinez A., Leroi C. et al. (2017). Conversion of Methyl Mercaptan to Hydrocarbons over H-ZSM-5 Zeolite. ACS Omega. 2(8): P. 4647–4656. doi: 10.1021/acsomega.7b00756
- [8] Huguét E., Coq B., Durand R., Leroi C., Cadours R., Hulea V. A highly efficient process for transforming methyl mercaptan into hydrocarbons and H₂S on solid acid catalysts. Appl. Catal., B 2013. P. 134–135.
- [9] Cammarano C., Huguét E., Cadours R., Leroi C., Coq B., Hulea V. (2014). Selective transformation of methyl and ethyl mercaptans mixture to hydrocarbons and H₂S on solid acid catalysts. Appl. Catal., B 2014. P.156–157.
- [10] Startsev A. N., Parmon V. N., Voroshina O. V. et al. (2004). Method of decomposition of hydrogen sulfide and (or) mercaptans. RU patent 2239594. (in Russ.).
- [11] Mashkina A.V., Grunvald V.R., Nasteka V. I., et al. (1990). Decomposition of alkanethiols to dialkyl sulfides and hydrogen sulfide. React. Kinet. Catal. Lett. 41, P.357–362.
- [12] Sehon A.H., Darwent B.deB. (1954). The Thermal Decomposition of Mercaptans. J. Am. Chem. Soc. 76. 19.P.4806–4810. <https://doi.org/10.1021/ja01648a011>
- [13] Baltrusaitis J., Bučko T., Michaels W., Makkee M., Mul G. (2016). Catalytic methyl mercaptan coupling to ethylene in chabazite: DFT study of the first C–C bond formation. Appl. Catal. B 187. P.195–203.
- [14] Butter S.A., Jurewicz A.T., Kaeding W.W.. (1975). Conversion of alcohols, mercaptans, sulfides, halides and/or amines. U.S. Patent 3894107.
- [15] Wachs E. (2003). Production of hydrocarbons from mercaptans. U.S. Patent A 200 030 060 672.
- [16] Ismagilov F.R., Podshivalin A.V. Nastek V.I. et al. (1993). Utilization of zeolite regeneration gases in the process of natural gas purification from mercaptans. Gas industry. N.4. P. 21-24. (in Russ.).
- [17]. Ismagilov F.R., Podshivalin A. V., Slushenko S. A. (1994). Method of purification of hydrocarbon gases from mercaptans. RU Patent 2023486. (in Russ.).
- [18] Gantman M.G. Ph. D. Thesis (Chemistry). Moscow, MSU, 2008 (in Russ.).
- [19] Rezvani A.M., Aghbolagh Z.S., Monfared H.H., Khandan S. (2019). J. Ind. Eng. Chem. V. 52. P.42. DOI: <https://doi.org/10.1016/j.jiec.2017.03.021>.
- [20] Angelescu E., Zavoianu R., Pavel O.D. et al. (2007). Rev. Chim.. V. 58. N.11. P. 1104.
- [21] Rezvani A.M., Zonoz F.M. // J. Ind. Eng. Chem. (2015). V. 22. P. 83. DOI: <https://doi.org/10.1016/j.jiec.2014.06.028>.
- [22] Rezvani A.M., Shaterian M., Akbarzadeh F., Khandan S. (2018). Chem. Eng. J.. V. 333. P. 537. DOI: <https://doi.org/10.1016/j.cej.2017.09.184>
- [23] Massalimova B.K., Altynbekova D.T., Jetpisbayeva G.D., Nauruzkulova S.M., Bakytzhan E.E., Sapi A.K., Sadykov V.A. (2019). Liquefied petroleum gas as raw materials for the production of liquid oxygen-containing organic compounds // News of the Academy of Sciences of the Republic of Kazakhstan. Series Chemistry and Technology. Vol. 3, N. 435, P. 38–43 (in Eng.).
- [24] Aristov Yu.I., Gordeeva L.G., Tokarev M.M., (2003). Method for producing a composite desiccant for gases and liquids. RU Patent 2244588 (in Russ.).
- [25] Kurochkin A.V., Ismagilov F. R. Method of purification of hydrocarbon gases (2012). RU patent 2502546. (in Russ.).

Publication Ethics and Publication Malpractice in the journals of the National Academy of Sciences of the Republic of Kazakhstan

For information on Ethics in publishing and Ethical guidelines for journal publication see <http://www.elsevier.com/publishingethics> and <http://www.elsevier.com/journal-authors/ethics>.

Submission of an article to the National Academy of Sciences of the Republic of Kazakhstan implies that the described work has not been published previously (except in the form of an abstract or as part of a published lecture or academic thesis or as an electronic preprint, see <http://www.elsevier.com/postingpolicy>), that it is not under consideration for publication elsewhere, that its publication is approved by all authors and tacitly or explicitly by the responsible authorities where the work was carried out, and that, if accepted, it will not be published elsewhere in the same form, in English or in any other language, including electronically without the written consent of the copyright-holder. In particular, translations into English of papers already published in another language are not accepted.

No other forms of scientific misconduct are allowed, such as plagiarism, falsification, fraudulent data, incorrect interpretation of other works, incorrect citations, etc. The National Academy of Sciences of the Republic of Kazakhstan follows the Code of Conduct of the Committee on Publication Ethics (COPE), and follows the COPE Flowcharts for Resolving Cases of Suspected Misconduct (http://publicationethics.org/files/u2/New_Code.pdf). To verify originality, your article may be checked by the Cross Check originality detection service <http://www.elsevier.com/editors/plagdetect>.

The authors are obliged to participate in peer review process and be ready to provide corrections, clarifications, retractions and apologies when needed. All authors of a paper should have significantly contributed to the research.

The reviewers should provide objective judgments and should point out relevant published works which are not yet cited. Reviewed articles should be treated confidentially. The reviewers will be chosen in such a way that there is no conflict of interests with respect to the research, the authors and/or the research funders.

The editors have complete responsibility and authority to reject or accept a paper, and they will only accept a paper when reasonably certain. They will preserve anonymity of reviewers and promote publication of corrections, clarifications, retractions and apologies when needed. The acceptance of a paper automatically implies the copyright transfer to the National Academy of Sciences of the Republic of Kazakhstan.

The Editorial Board of the National Academy of Sciences of the Republic of Kazakhstan will monitor and safeguard publishing ethics.

Правила оформления статьи для публикации
в журнале смотреть на сайте:

www.nauka-nanrk.kz

<http://chemistry-technology.kz/index.php/en/arhiv>

ISSN 2518-1491 (Online), ISSN 2224-5286 (Print)

Редакторы: *М. С. Ахметова, Д. С. Аленов, А. Ахметова*
Верстка на компьютере *А.М. Кульгинбаевой*

Подписано в печать 03.12. 2020.
Формат 60x881/8. Бумага офсетная. Печать – ризограф.
9,1 п.л. Тираж 300. Заказ б.